

One-step application. No tools needed!

REUSE

series

wiring clamps
bands
board fasteners



Think efficiency and usability. Environmentally-friendly fasteners are here!





Kitagawa GmbH

Elbinger Strasse 3-5
D-63110 Rodgau

tel: 06106-8524-0
fax: 06106-8524-30

email: sales@kitagawa.de
website: www.kitagawa.de

For over 10 years, Kitagawa has been taking the environment into serious consideration when designing new products. Taking functionality and usability into consideration, we have made our products environmentally friendly to to conserve limited natural resources. Here, we proudly present our Reuse series.

<p style="writing-mode: vertical-rl; transform: rotate(180deg);">DESIGN</p>	<p style="text-align: center;">other maker's recyclable parts</p> <p>Styles and sizes are limited and not easily customized</p>	<div style="text-align: center;">  </div> <p>Pick and choose from abundant styles and sizes according to your design needs</p> <p>Space-saving, easily snaps-fit into small spaces</p> <p>Round hole installation makes it easy to switch out parts</p> <div style="display: flex; justify-content: space-around; align-items: center;"> <div style="text-align: center;">  <p>space-saving snap</p> </div> <div style="text-align: center;">  <p>round hole installation</p> </div> </div>
	<p style="writing-mode: vertical-rl; transform: rotate(180deg);">PRODUCTION</p>	<p>Limited functionality</p> <p>Part doesn't fit into the installing hole</p> <p>Installation requires nipper or driver tools</p>
<p style="writing-mode: vertical-rl; transform: rotate(180deg);">RECYCLING/ MAINTENANCE</p>	<p>Necessary to remove entire panel to gain access to the back side when removing the part</p> <p>Product is easily scratched or damaged upon removal of part rendering it unusable</p> <div style="text-align: center;">  </div>	<p>Install and remove the part from one side only without using tools or removing the entire panel</p> <p>Minimizes possibility of damage to the product during part removal</p> <div style="text-align: center;">  </div>

I Reuse Snap T Type - Twist Removal



SPACE SAVING

Existing snap



T type snap



Reduced rear protrusion

Compared to existing snap products, Reuse snaps do not occupy as much space on the back side

MORE EFFICIENT



Just "twist" to install and/or remove

Easy to install without tools and removes from same side. You won't have to cut off the bottom from the rear of the board for removal.

With Anti-Fallout Lock

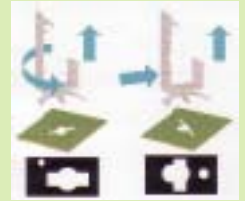

II Reuse Snap D Type - Slide Removal



MORE EFFICIENT



Just "slide" to install and/or remove

Round hole Installation



Round hole - no need to make odd-shaped hole for installation

SPACE SAVING

Reduced rear protrusion



III Reuse Snap S Type - Push Removal



Round hole Installation



MORE EFFICIENT

Just "push" the bar for removal

Tension Mini Clamp (RTMC-01T VO)

Will keep even thin cables firmly in place using new "tension" mechanism

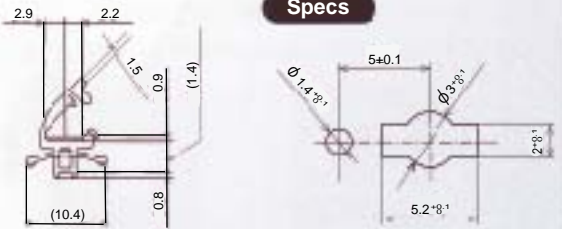
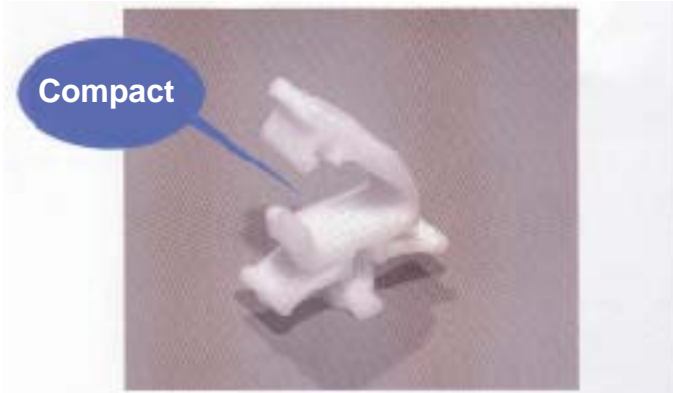

(Unit:mm)

Item #	Application Board	Packaging Unit
UL RTMC-01T VO	t1.2~1.6	1,000

Reuse Lock Mini Clamp (RLMC)

Locks after inserting cable to prevent cable straying from the clamp

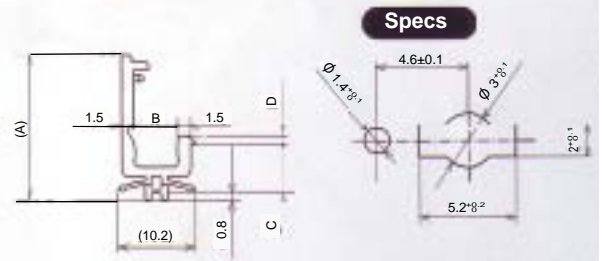

(Unit:mm)

Item #	A	B	C	D	Application Board	Packaging Unit
UL RLMC-01T VO	17.3	5.6	3.8	1.7	t0.8~1.2	1,000
UL RLMC-05T VO	19.8	6.0	3.7	4.0		

Reuse Wire Sadle (RWS)

Clamps bulk of cables in one easy to use step

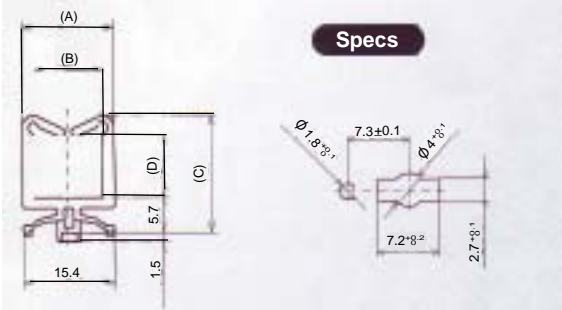

(Unit:mm)

Item #	A	B	C	D	Application Board	Packaging Unit
UL RWS-1T VO	15.5	11.5	14.2	5.0	t0.8~1.6	200
UL RWS-2T VO			19.2	10.0		
UL RWS-3T VO	28.2	19.0				
UL RWS-4T VO	36.2	27.0				
UL RWS-1015T VO	20.0	16.0	20.4	11.2		500

Reuse Wire Sadle (RWS)

Large capacity clamp- secures many cables at once

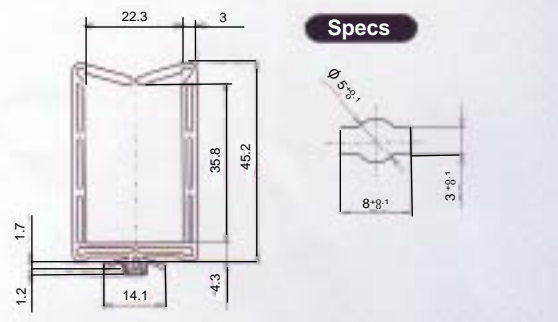

(Unit:mm)

Item #	Application Board	Packaging Unit
UL RWS-3522T	t0.8~1.6	1,000

CKT Clamp (CKT)

Only 1mm protrusion, very effective in tight spaces

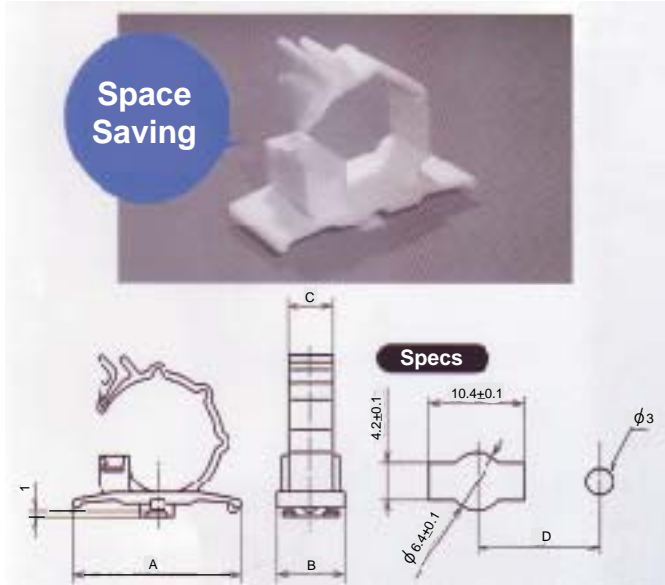

(Unit:mm)

Item #	A	B	C	D	Largest Bundle Diameter	Application Board	Packaging Unit
UL CKT-05 VO	23.0	10.0	6.0	10.0±0.1	∅ 5.4	t1±0.2	100
UL CKT-07 VO					∅ 6.5		
UL CKT-10 VO					∅ 10.0		
UL CKT-13 VO	30.0	12.0	8.0	13.5±0.1	∅ 14.4		
UL CKT-16 VO					∅ 17.5		
UL CKT-20 VO	36.0	14.0	10.0	16.5±0.1	∅ 20.0		

Reuse Clamp (RBWS-D)

New, easy lock-unlock mechanism

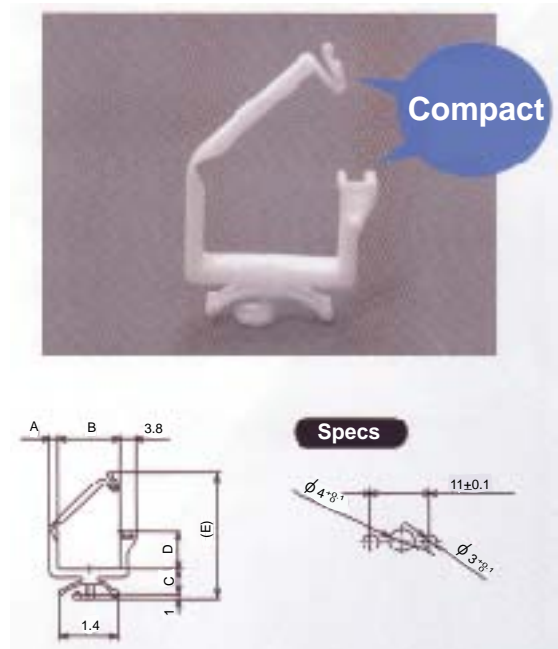

(Unit:mm)

Item #	A	B	C	D	E	Application Board	Packaging Unit
UL RBWS-0406D VO	1.5	6	4.5	3.7	17.13	t0.5±1.6	500
UL RBWS-0510D VO		10	5.0	4.7	21.61		
UL RBWS-1015D VO		15		9.7	31.35		
UL RBWS-1515D VO	1.8		6.0	14.7	36.35		
UL RBWS-2020D VO	2.0	20		19.7	45.03		

Reuse Clamp (RLWS-T)

Efficient disassembly and maintenance

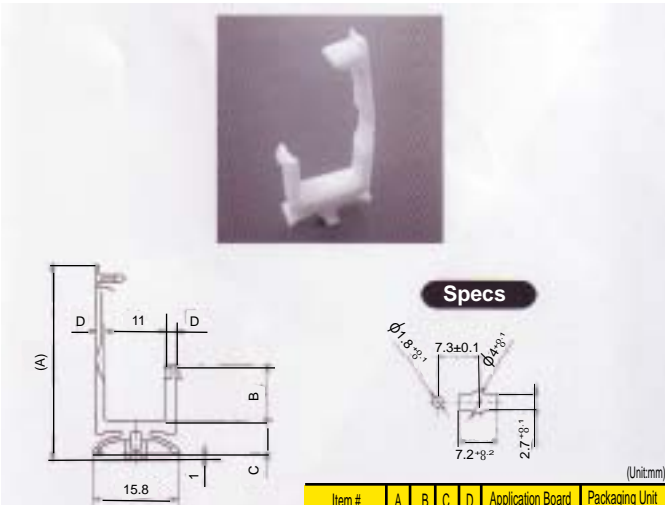

(Unit:mm)

Item #	A	B	C	D	Application Board	Packaging Unit
UL RWLS-1T VO	29.1	4.9	5.3	1.5	t0.8-1.6	1,000
UL RWLS-2T VO	32.8	7.4	5.7	2		
UL RWLS-3T VO	35.6	9.9	5.8			

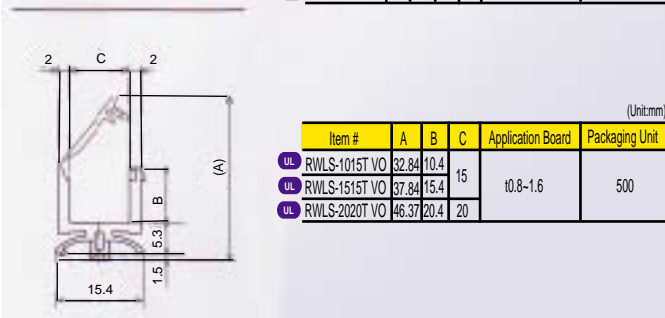

(Unit:mm)

Item #	A	B	C	Application Board	Packaging Unit
UL RWLS-1015T VO	32.84	10.4	15	t0.8-1.6	500
UL RWLS-1515T VO	37.84	15.4			
UL RWLS-2020T VO	46.37	20.4	20		

Reuse Clamp (RWLS-TL)

Accommodates wide range of installation board thicknesses

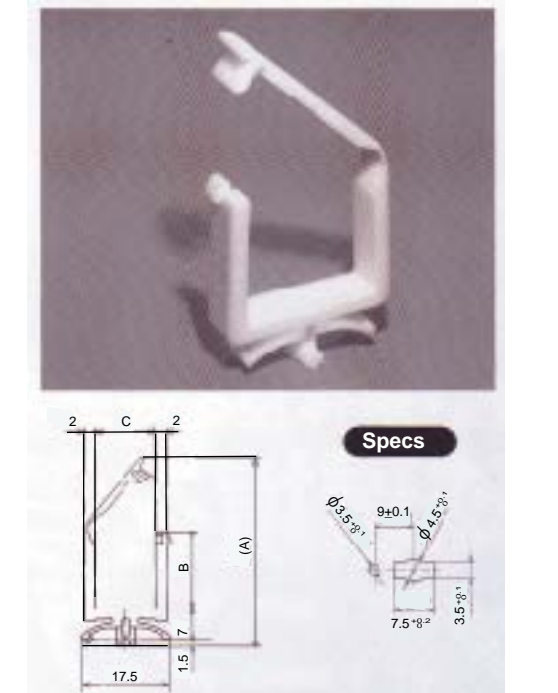

(Unit:mm)

Item #	A	B	C	Application Board	Packaging Unit
UL RWLS-0501TL	26.0	5.4	10	t0.8-3.2	500
UL RWLS-1010TL	31.0	10.4			
UL RWLS-1515TL	39.54	15.4	15		
UL RWLS-2020TL	48.07	20.4	20		

Reuse Clamp (RBWS-S)

New easy-access lock system



Efficient Lock System

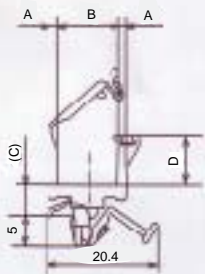

Specs

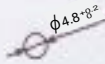

(Unit:mm)

Item #	A	B	C	D	Hole Diameter	Application Board	Packaging Unit
UL RBWS-3S VO	1.8	11	5.7	9.7	φ4.8±0.2	t0.5~1.6	500

Free Clamp (FLC)

Adjustable for your needs, easy to unlock

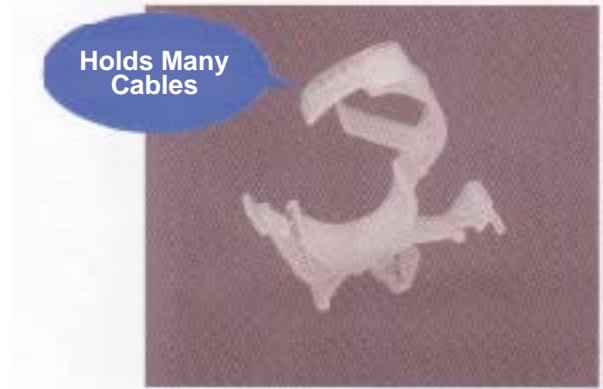

Holds Many Cables

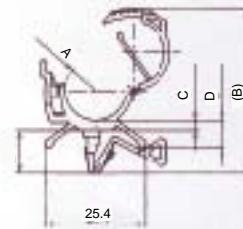

Specs

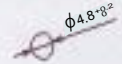

(Unit:mm)

Item #	A	B	C	D	Bundle Diameter	Application Board	Packaging Unit
UL FLC-10S	R8	42.2	2.4	6.6	φ 7~14	t0.8~2	500
UL FLC-20S	R13	59.4	3.4	7.6	φ14~22		100

Reuse Clamp (RLWS-S)

High holding power, secures even the smallest fo cables

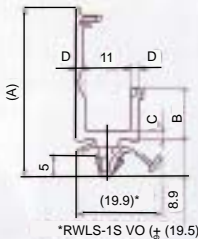

Specs

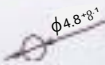

(Unit:mm)

Item #	A	B	C	D	Application Board	Packaging Unit
UL RLWS-1S VO	32.8	6.4	1.5	1.5	t0.5~1.6	1,000
UL RLWS-3S VO	39.4	11.9	2.0	2.0		

Reuse Band (RSG)

Easy, tool-free installation and maintenance

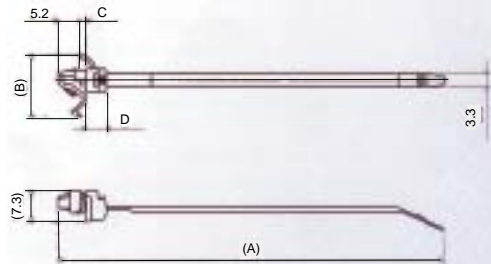

(Unit:mm)

Item #	A	B	C	D	Installation Hole Diameter	Application Board	Bundle Diameter	Packaging Unit
UL RSG-100 VO	100.0	16.2	1.8	5.9	φ 4.8±0.2	t0.5~1.6	φ1~20	500
UL RSG-130 VO	133.5	17.9	2.7	6.2		t0.6~2.4	φ1~24	

Clamp (FCR) / Flat Cable Clamp (FCT-6010)

Space saving clamp to secure cables directly against the board

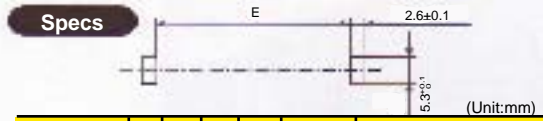
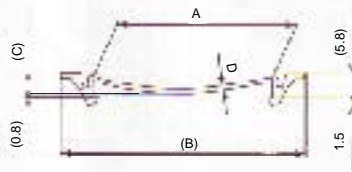

Item #	A	B	C	D	E	Application Board
FCR-15 VO	15	27	2.6	0.8	15±0.1	t0.8~1.6
FCR-30 VO	30	42	2.9	1.0	30±0.1	
FCR-35 VO	35	47		35±0.1		
FCR-40 VO	40	57	1.2	45±0.1		
FCR-60 VO	60	72	1.5	60±0.1		

Minimal rear protrusion, ideal for tight spaces

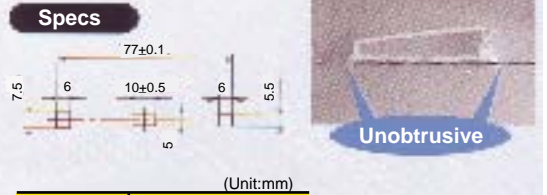
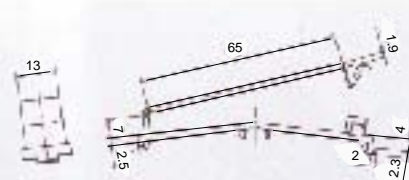

Item #	Application Board
FCT-6010	t1±0.2



Reuse Edge Spacer (RES) / Reuse Pierce Hold (RPH)

Use together to hold and secure board

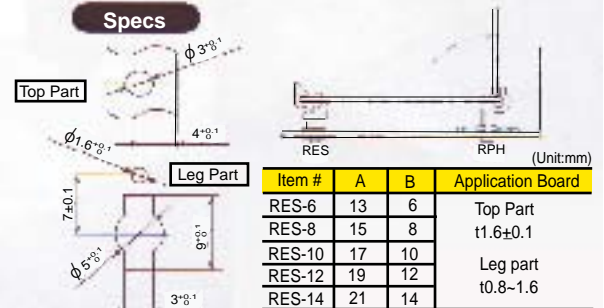
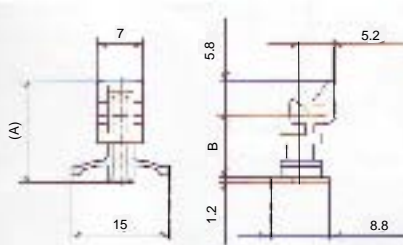

Item #	A	B	Application Board
RES-6	13	6	Top Part
RES-8	15	8	t1.6±0.1
RES-10	17	10	Leg part
RES-12	19	12	t0.8~1.6
RES-14	21	14	

Used along with Reuse Edge Spacer to hold the board and move it 90°

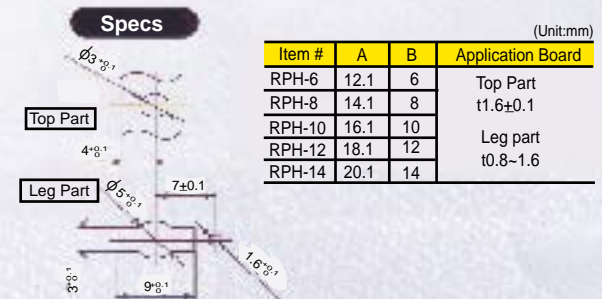
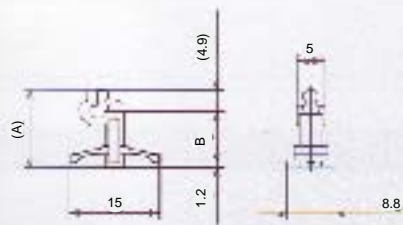

Item #	A	B	Application Board
RPH-6	12.1	6	Top Part
RPH-8	14.1	8	t1.6±0.1
RPH-10	16.1	10	Leg part
RPH-12	18.1	12	t0.8~1.6
RPH-14	20.1	14	

Reuse Card Holder (RCH-40-VO)

Holds sub board and secures it to the main board, even in tight areas. Sub board slides off easily in one step.

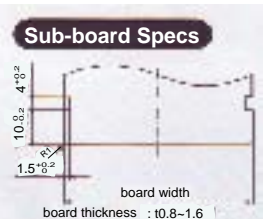
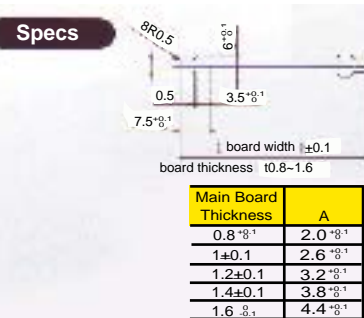
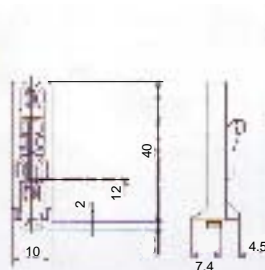
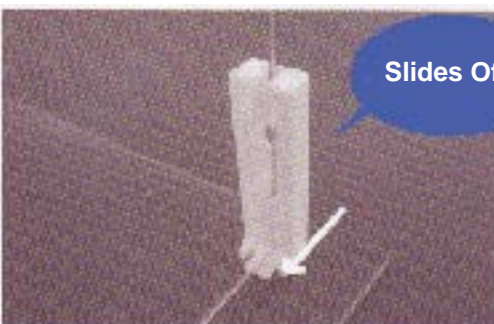

Main Board Thickness	A
0.8 ^{+0.1}	2.0 ^{+0.1}
1±0.1	2.6 ^{+0.1}
1.2±0.1	3.2 ^{+0.1}
1.4±0.1	3.8 ^{+0.1}
1.6 ^{+0.1}	4.4 ^{+0.1}